

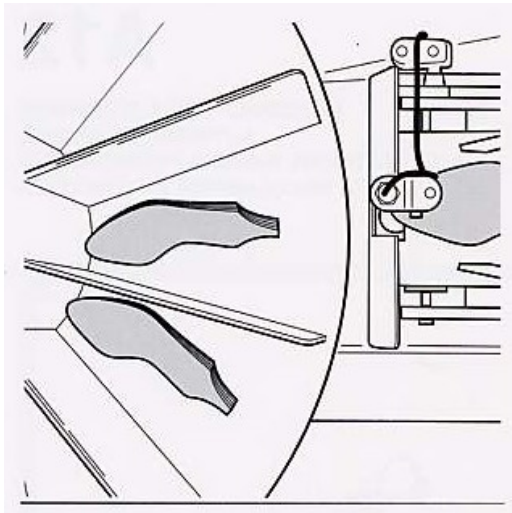

# A12 *Automatic stacker*

TECHNICAL DATA	
Net weight	kg 224
Production	1800 pairs/h
Installed power	kW 0.55
Size	mm 1500 x 980 x 1060 h



The automatic stacker efficiently handles pieces from a production cycle, featuring a conveyor belt and a turntable divided into 12 sectors. A programmable work counter allows for precise presetting of the number of pieces in each sector. This compact machine is ideal for integration into any production cycle with multiple operations.



American Shoe Machinery  
 100 Cummings Center, Ste. 140A  
 Beverly, MA 01915 USA  
 800-777-2762 - 978-524-0168  
 Email: [info@asmc-us.com](mailto:info@asmc-us.com)  
 Website: [www.asmc-us.com](http://www.asmc-us.com)